

Drive adapter

Standard configurations and machine specific executions upon request

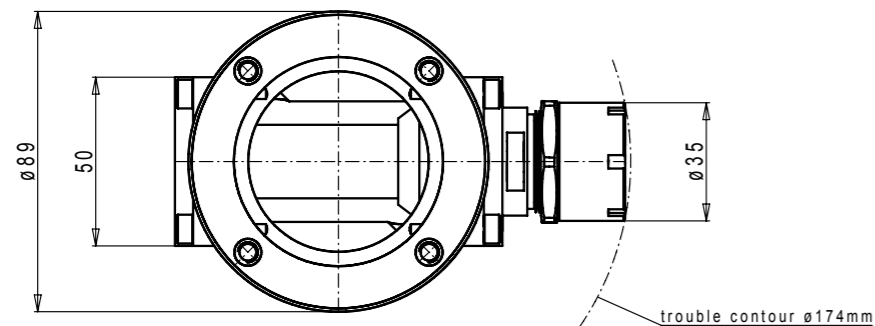
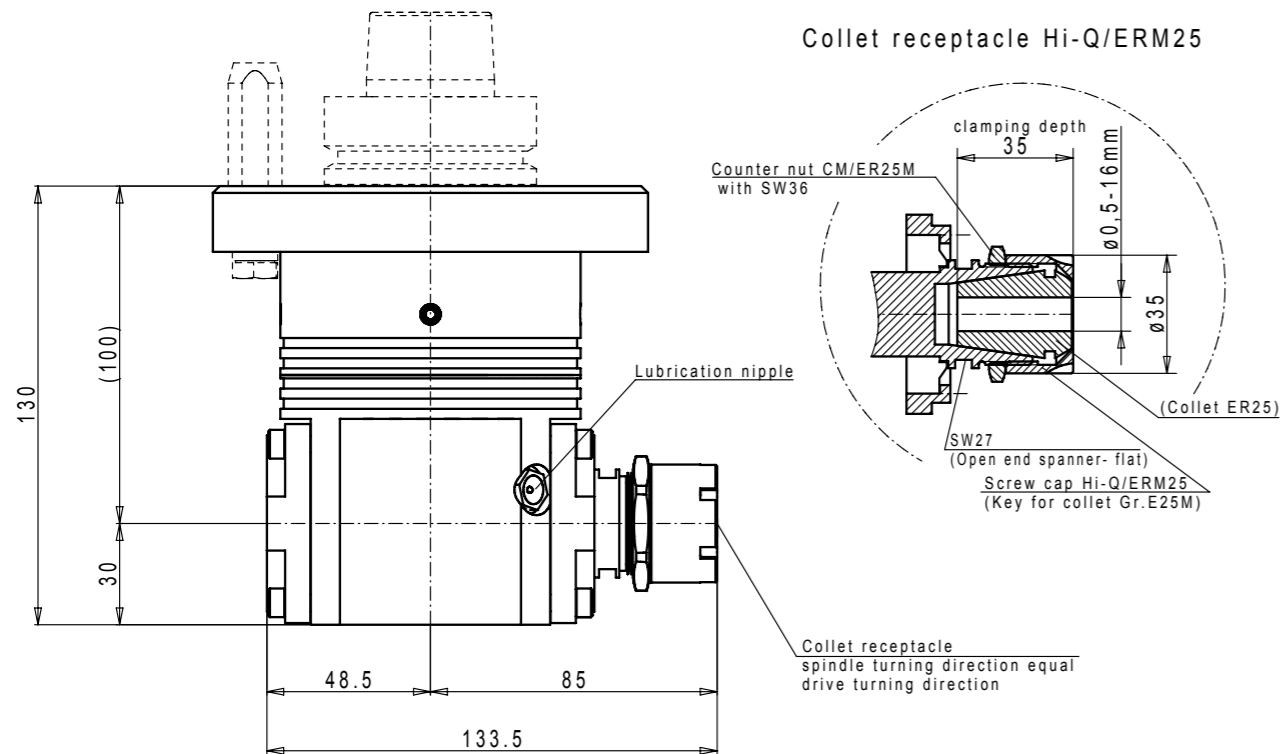

Technical features

Item Id.	EP-030651
drive turning direction	R.H./L.H.
drive speed max.	permanent operation 645 – 10.968 rpm
drive speed max.	interval operation 645 – 12.903 rpm
number of spindles	1
spindle position	horizontal
tool receptacle	1x Hi-Q/ERM25 DIN6499-C (8°) for collet ER25 DIN 6499-B (ø0,5-ø16 mm)
turning direction of tool receptacle	1x equal to drive turning direction
gear ratio	1 : 1,55 – gear driven
spindle speed max.	permanent operation 1.000 – 17.000 rpm
spindle speed max.	interval operation 1.000 – 20.000 rpm
drive capacity	3,0 kW
weight with drive adapter	approx. 4,00 kg

Optional accessories:

Key for collet E 25M	Item Id. 137002
Open end spanner SW 27 flat	Item Id. 131027
Open end spanner SW 36	Item Id. 131036
Lubrication press	Item Id. 980003

The angular heads of the series G06-1.1 have a continuous machining spindle. The drive speed is transmitted in a ratio 1:1,55 to the tool receptacles. The maximum spindle speed in interval operation is 20,000 rpm.

Variants on demand!

