

**SACCARDO**<sup>®</sup>

**SBC**

ELECTRIC MOTORS  
FOR CUTTING AND MILLING  
AIR COOLING

电动机  
用于切削和铣削  
空气冷却



MADE IN  
ITALY

**PROCESSING:** Cutting and edging  
**用途:** 切割和镶边

**IDEAL FOR:** Wood, Stone  
**行业:** 木工、石材

## Overall and fitting dimensions

总尺寸和装配尺寸

ST

Standard electric motor with blade-holding flanges and locking nut  
带叶片固定法兰和锁紧螺母的标准电动机

### 76 · ST

	L1	L2	L3
A	445	369	335
B C	510	434	400
D E	570	494	460

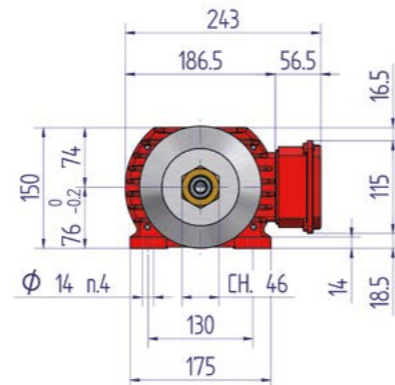
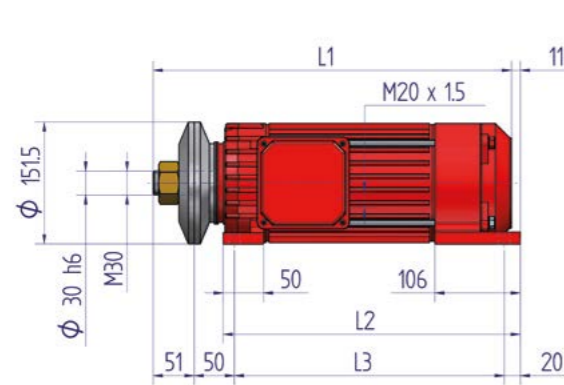

SBC 76 ST

## Overall and fitting dimensions

总尺寸和装配尺寸

ST

Standard electric motor with blade-holding flanges and locking nut  
带叶片固定法兰和锁紧螺母的标准电动机

### 160 · ST

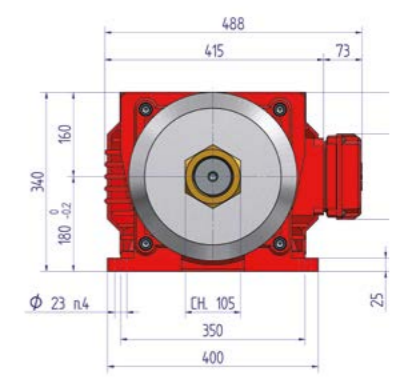
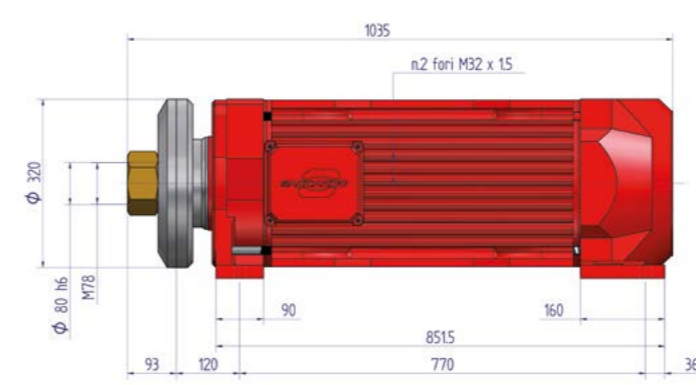

SBC 160 ST

### 142 · ST

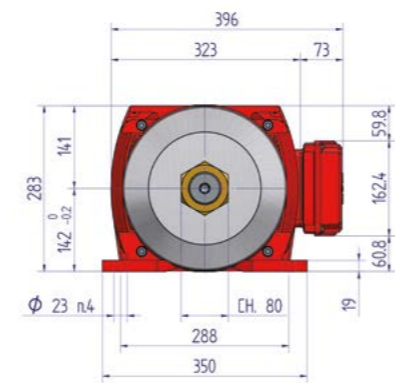
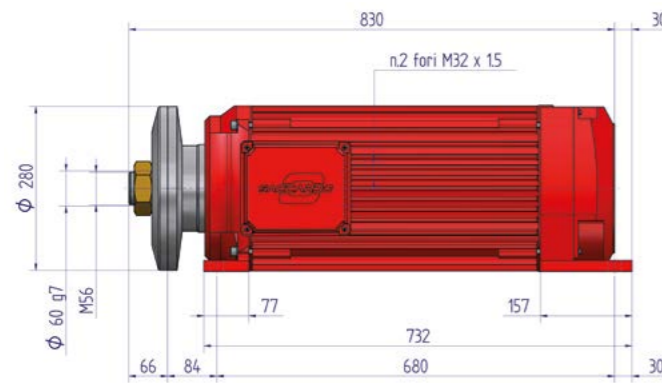

SBC 142 ST

### 200 · ST

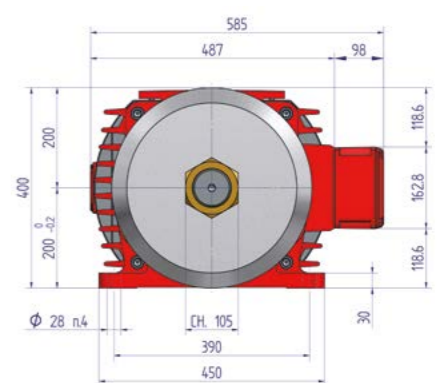
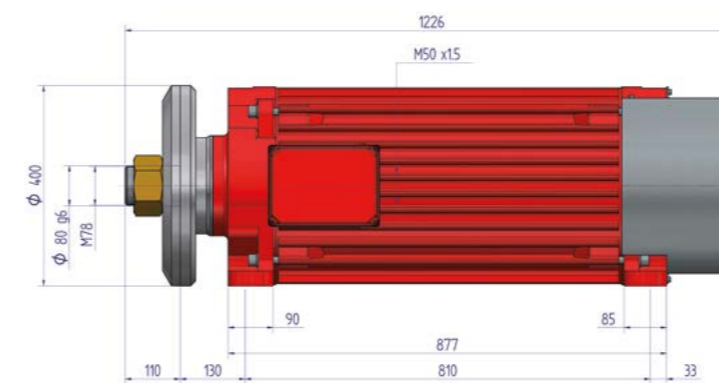

SBC 200 ST

## Overall and fitting dimensions

总尺寸和装配尺寸

FR

Electric motor with a flat flange for the disc direct fixing

带光面法兰的电动机，用于盘片的直接固定

### 76 · FR

	L1	L2	L3
A	398	369	335
B C	463	434	400
D E	523	494	460

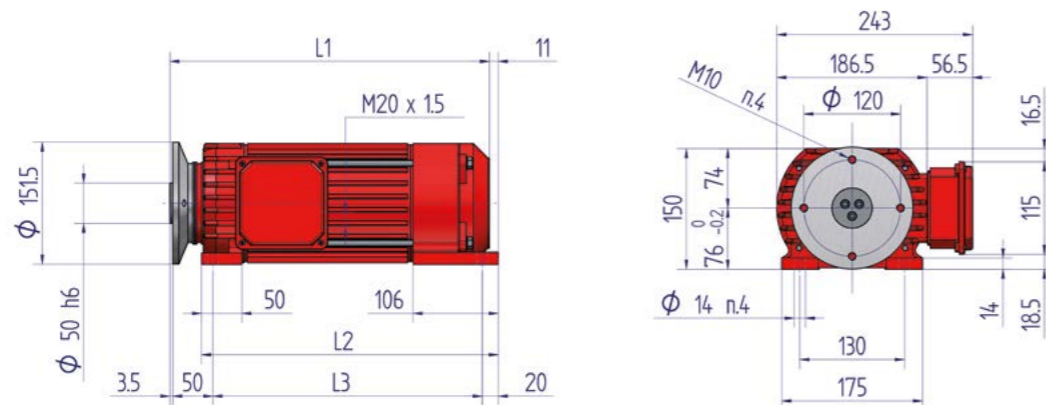

SBC 76 FR

FR

## 400 V / 50 Hz Rated data

额定转速

Size	S1 Duty - Rated Values				S6 - 60% Duty - Rated Values				Weight (kg)
	Power	Current		Speed	Power	Current		Speed	
	(kW)	(CV)	(A)	(rpm)	(kW)	(CV)	(A)	(rpm)	
76 A/2	2,6	3,6	5,8	2.840	3,15	4,3	7	2.825	31
76 B/2	3,3	4,5	7,4	2.850	3,9	5,5	8,5	2.835	34
76 C/2	4,2	5,8	9,3	2.855	4,9	6,8	11,1	2.840	37
76 D/2	4,7	6,5	10,4	2.860	5,6	7,5	12,6	2.845	40
76 E/2	5	6,8	10,9	2.865	5,9	8	12,9	2.850	44
142 B/2	44	60	82	2.935	53	72	98	2.900	236
142 C/2	55	75	102	2.935	66	90	120	2.900	265
200 A/2	80	109	140	2.935	95	129	165	2.900	565
76 A/4	2,2	3	5,6	1.390	2,6	3,5	6,7	1.370	33
76 B/4	3,1	4,3	8	1.405	3,7	5	9,5	1.385	37
76 D/4	4	5,5	10	1.415	4,9	6,6	12	1.395	40
76 E/4	4,7	6,5	10,6	1.405	5,5	7,5	12,4	1.390	43
142 A/4	36,7	50	72	1.460	44	60	84	1.440	229
160 A/4	47,5	65	93	1.470	57	77,5	110	1.450	350
200 A/4	70	95	130	1.480	80	109	145	1.450	605
142 A/6	26,5	36	58	965	31,8	43,2	69,6	955	220
160 A/6	35,5	48	77	970	42,6	57,6	92,4	960	345
200 A/6	65	88	120	970	75	102	135	960	645
142 A/8	22	30	50,5	725	26,5	36	58,5	710	215
160 A/8	30	40,5	68	725	35,5	48	77,5	710	350
200 A/8	50	68	100	725	58	79	115	710	685
160 A/10	23	31	78	560	25,5	35	88	545	350
200 A/10	40	54	80	570	46	63	92	560	685
200 A/12	33	45	70	485	38	52	80	475	685
76 C/4-2	3,3/4,4	4,5/6	8,1/9	1.410/2.855	4/5,3	5,5/7,1	9,2/11	1.395/2.835	36
142 A/4-2	25,5/33	35/45	54/70	1.435/2.900	31/40	42/54	65/84	1.415/2.880	220
142 A/6-4	22/30	30/40	41/61	965/1.440	26,4/36	36/48	49/73	950/1.400	218

S1 (Continuous service): Operation under a constant load with a duty cycle which allows to reach the thermal balance.

S6 (Uninterrupted periodical service): Operation including a series of identical cycles, each of them made up of a constant load operation period and a load less operation period. There are not resting periods. The processing period does not allow the thermal balance to be reached.

S1 (连续工作)：在恒定负载下运行，占空比可达到热平衡。

S6 (不间断定期工作)：运行包括一系列相同循环，每个循环均由恒定负载运行时间段和无载运行时间段组成。不存在休息时间。加工期间不允许达到热平衡。

More electrical details are available on demand

可按需提供更多电气详情

## Technical features 技术特点

The maximum rotation speed that can be reached using a frequency variators is:

使用变频器可达到的最大转速为:

Only disk  
仅有盘片

SBC 76	4.500 rpm
SBC 142	3.800 rpm
SBC 160	2.400 rpm
SBC 200	2.400 rpm

## Terminal box position 接线盒位置

The terminal boxes are arranged for the cable passing-through in compliance with the EN 62444-10 standard.

布置用于电缆通过的接线盒符合EN 62444-10标准。

SBC 76	1 hole / 1 孔	M20 x 1,5	SBC 142	2 holes / 2 孔	M32 x 1,5
SBC 160	2 holes / 2 孔	M32 x 1,5	SBC 200	1 hole / 1 孔	M50 x 1,5

## Protection degree 防护等级

IP 55

5  Partially protected against dust  
部分防尘

5  Protected against water jets from any direction  
防护任何方向的水流喷射



The manufacturer is responsible for the correct evaluation of the protection degree necessary for his application and for using the appropriate protections.

制造商有责任正确评估其应用所需的防护等级，并采用适当的防护措施。



Do not use a high-pressure water washing-machine.

请勿使用高压水流清洗机器。

## Tools recommended dimensions and suggested rotations per minute

推荐刀具尺寸和建议每分钟转数

	 [ø mm]	 [ø mm]	Marbles 大理石 [40/50 m/s]	Sandstones 砂岩 [55/65 m/s]	Hard granites 硬质花岗岩 [25/30 m/s]	Soft granites 软质花岗岩 [32/40 m/s]
SBC 76	151,5	450	1.700/2.100	2.300/2.800	1.000/1.300	1.300/1.700
SBC 142	280	1.100	700/870	950/1.150	440/520	555/700
SBC 160	320	1.400	550/680	750/900	340/410	440/550
SBC 200	400	1.600	480/600	660/790	300/360	380/480



Adequate protection guards are strongly recommended.

强烈建议采用充分的防护措施。

The product features described in the present catalogue are approximate. Saccardo Elettromeccanica S.r.l.u. reserves the right to make any modifications to the components whenever deemed necessary, without prior notice, in order to enhance the product quality, based on the technical knowledge acquired and the current state of the art.

本目录中描述的产品功能类似。Saccardo Elettromeccanica S.r.l.u.保留基于获得的技术知识和当前的技术水平，为提高产品质量而在必要时对组件进行任何修改的权利，恕不另行通知。



**SACCARDO ELETTROMECCANICA S.r.l.u.**

地址: Via Casa Celeste, 10

36014 Santorso (VI) - ITALY

T. / 电话: +39 0445 540542 - F. / 传真: +39 0445 540538

VAT Code / 增值税号: IT00899480248

www.saccardo.it - info@saccardo.it

**中国总代理**

**安德鲁信重工江苏有限公司**

地址: 江苏省江阴市澄江东路3号

手机: 18961619099

邮箱: info@andrewen.com

网址: www.andrewen.com

